



PT-PSE105GWS-E

Industrial DC Input Fiber PoE Injector

Product Overview

PT-PSE105GWS-E is a single-port, industrial-scale, boost PoE injector with fiber port. It provides 55Vdc, 1.1A power for remote PDs over full 4 pairs output with 6KV (10/700us) surge protection. It supports 10/100/1000Mbps of data speed. It works for 60W PoE PDs, such as wireless access points, network cameras, Voip phones and other high power Ethernet terminals. It is also compatible and safe to use with any IEEE802.3af/at, PoE++ compliant terminals. It works as a switch, data is interoperable between PoE port and SFP port.

PT-PSE105GWS-E is designed for indoor use. It works with input voltage of 12-48Vdc and operates under -40 °C to 65 °C. It has detection chip inside, which will detect and classify PD before powering it. It will not apply power until a standard-compliant PD is detected. The effective distance is 100 meters over Cat5e/Cat6 cables.

This model equipped standard DIN rail mounting bracket, which can easily jam into the guide rail.

Product Profile

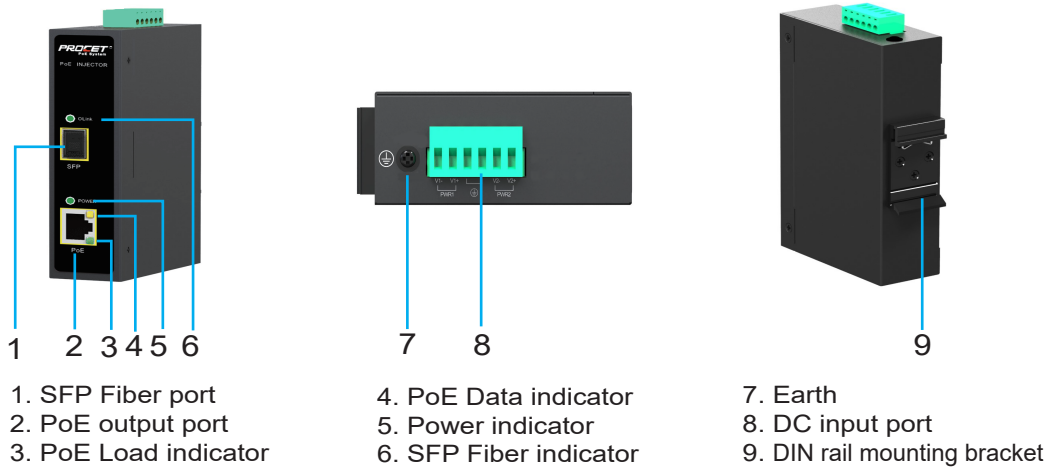

Product Working Diagram

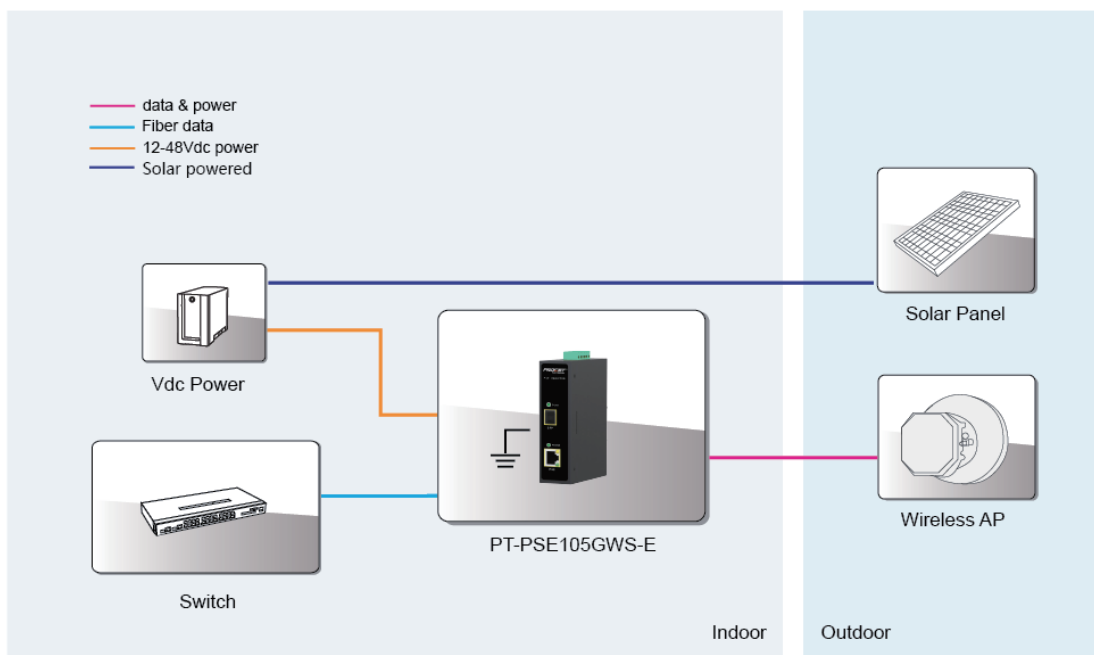

Specification

Standard

- IEEE802.3 10Base-T Ethernet
- IEEE802.3u 100Base-Tx Fast Ethernet
- IEEE802.3ab 1000Base-T Gigabit Ethernet
- Full compliant with IEEE802.3af/at, PoE++
- RoHS Compliance
- WEEE Compliance

Input & Output

- Input :12-48Vdc 6.0A
- Output: 55Vdc 1100mA
- Power Pins: 4/5(+), 7/8(-) & 3/6(+),1/2(-)
- Data Speed: 10/100/1000Mbps

Working Environment

- Operating Temperature: -40℃ to 65℃
- Operating Humidity: 20% to 80%, non-condensation
- Storage Temperature: -40℃ to 85℃
- Storage Humidity: 10% to 90%, non-condensation
- Operating Altitude: up to 5000meters

PoE Surge Protection

- Protected line: 1,2,3,4,5,6,7,8
- Common mode surge protection(10/700us): 6KV
- Differential mode surge protection (10/700us): 1.5KV

Mechanical Characteristics

- Case: Metal
- Color: Black
- Mounting: DIN-rail
- IP Rated: IP40
- Size: 144.5mm X 95mm X 35.4mm
- Weight: 485g

EMI

- FCC CFR47 Part 15, EN55024, EN55032

EMS

- IEC61000-4-2(ESD) $\pm 6kV$ (contact), $\pm 8kV$ (air)
- IEC61000-4-3(RS) 10V/m(80MHz~2GHz)
- IEC61000-4-4(EFT) Power Port: $\pm 2kV$; Data Port: $\pm 1kV$
- IEC61000-4-5(Surge) Power Port: $\pm 1kV/DM$, $\pm 2kV/CM$
- IEC61000-4-6(CS) 10V(150kHz~80MHz)

Immunity

- IEC60068-2-6(Vibration)
- IEC60068-2-27(Impact)
- IEC60068-2-32(Free Fall)

LED Indicator

- Power Indicator : Green
- PoE Load Indicator : Green
- SFP fiber indicator: Green
- PoE data indicator: Yellow

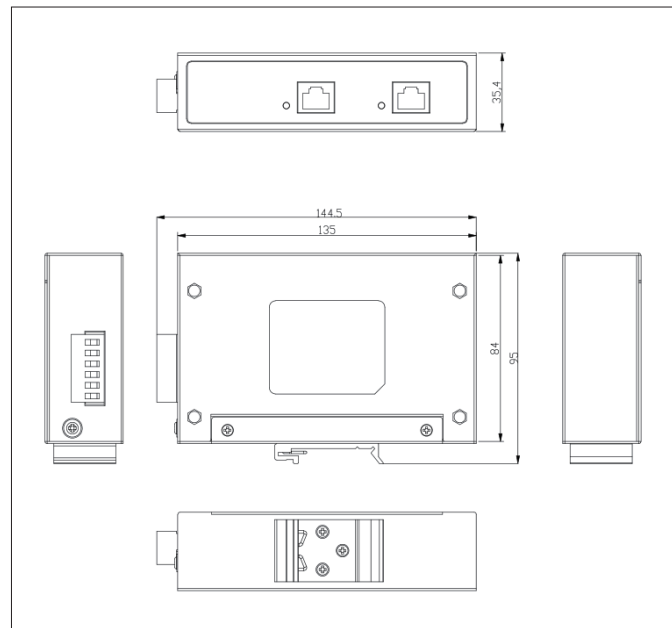

Order Info. PT-PSE105GWS-E

55Vdc/1.1A/1000Mbps/(4,5+,7,8-) & 3/6(+),1/2(-) /Surge Protection/Active

Packing

PT-PSE105GWS-E
Ground lug Wire: 16AWG
Manual x 1



This document belongs to PROCET company. It is not allowed to reproduce and modify without the original author's permission. It is PROCET's policy to improve its products as new technology, components, software, and firmware at any time. PROCET, therefore, reserves the right to change specifications without prior notice. (2019.07)